

Domusnext[®] 2.0 G1.6 & G4 EXT D

A comprehensive range of smart and integrated gas meters
small and easy to install displaying readings
in standard cubic meters,
no external devices needed for conversion and for communication,
for an accurate billing transparent to the end customer.



Domusnext[®] G1.6 ÷ G6 meters are available with the following communication technologies:

GPRS
NB-IoT
Mbus 169 MHz
Mbus 868 MHz

Integrated shut-off valve.

MAIN BENEFITS

An innovative static measurement principle

Measurement is intrinsically compensated in temperature and independent from pressure. Measurement is displayed directly in standard cubic-meters*.
The measurement technology is based on a MEMS "Micro Thermal Flow Sensing" principle. Two temperature sensors are symmetrically placed around a micro-heating element: under stopped-flow conditions, both sensors measure the same temperature. As the flow rate increases, heat is carried away from the upstream sensor towards the downstream sensor and the measured temperature difference between the two sensors is proportional to the mass flow rate.

Transparent billing to the end customer

Memory storage of daily or hourly consumption, with frequent communication of data, means customer invoicing can be transparent and timely, referring to the exact billing period, with low operating costs.

Gas recognition

The accuracy of measurement is not affected by changes in the chemical composition of the distributed gases within the 2nd family groups H and L (as defined by EN 437:2003). By measuring specific gas properties, a pre-set auto-calibration process guarantees the required accuracy levels without any additional adjustment.
The meter is also able to operate in air (test phase), by calibrating itself accordingly without any additional adjustment.

Tariff management

Management of 3 tariffs, which can be programmed for weekdays, weekends/public holidays and daylight saving time.

Accuracy of measurement at every temperature and at every pressure

Domusnext[®] meters provide an exact measurement of supplied gas in standard m³, avoiding the use of annual average temperatures and pressures, which inevitably lead to approximate values and errors of estimation. These errors then affect the amount billed.

Innovation and reliability

Despite being highly innovative, Domusnext[®] meters have passed the most stringent reliability tests, conducted by notified body and designated laboratories recognised at European level. This certifies the robustness of MeteRSit meters and the accuracy of their measurements, even at high concentrations of dust and contaminants in the gas distribution networks. The high accuracy of the measuring principle ensures the gas meter compliance with the MID (Measuring Instruments Directive). Such micro-thermal measuring principle is also commonly used in laboratory instruments. Resistance to contaminants and dust is ensured by design.

Connectivity

The meter is equipped with an Integrated high performance antenna.
The application software can be remotely updated.

Noise level

Thanks to the static technology adopted, the meter has a very low level of noise and practically no wear. This characteristic is well appreciated in particular for domestic application.

* According to UNI EN ISO 13443 standard



www.metersit.com

Main Office

Via Felice Casati 44
20124 Milano, Italia
Tel. +39 02 67841211
email: info@metersit.com

Registered Office

Viale dell'Industria 31-33
35129 Padova, Italia
Tel. +39 049 8293111

Production Plants

Via Achille Grandi 6
45100 Rovigo, Italia
Sos. Cristianului 34
500053 Brasov, Romania

Domusnext[®] 2.0 G1. & G4 Ext

Technical data

Type Approval

Measuring range

Standard temperature for volume output

Operating temperature

Standard pressure for volume output

Gas application

Max. operating pressure

Accuracy class

Measuring Accuracy Q_{min} Q_t

Measuring Accuracy Q_t Q_{max}

Max. Pressure drop

Nr. of tariffs

Depth of consumption registers @ 1 day rate

Depth of consumption registers @ 1 hour rate

Nominal Diameter DN

Inlet & Outlet Distance

Resistance to water, dust and impact

ATEX

Display

Optical port

Valve

Maximum leakage for the valve

Battery supply

Communication Protocol

G1.6 - G4 EXT

MID T10362 Module B
and CE-193 Module D

G1.6 = 0.016 – 2.5 m³/h

G4EXTD = 0.016 – 6.0 m³/h;

15 °C ; 0°C; 20°C

-25 °C to 55 °C

1013.25 mbar

2nd Family Group H or L (EN 437)

500 mbar

1.5

± 3.0 %

± 1.5 %

<2 mbar at Q_{max}

3

72 days

72 days

G 1" 1/4 - ISO 228/1

110 mm; 130 mm

IP 66, IK 08

zone 2

Ex II 3 G Ex nA IIA T6 Gc

2 lines multi-segment display,

Upper line 7 characters

Lower line 9 digits

Automotive range -30°C to +85°C

EN 62056-21

Compliance with EN 16314

120 cc/h at Pin = 500 mbar

2 x 3.6 V lithium cell

DLMS/Cosem

AES 128-bit encrypted communication

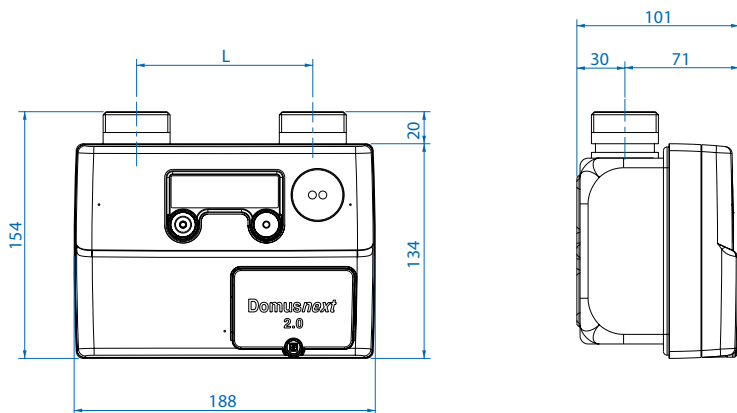

Model	ØD	L	Weight
G1.6 ÷ G4 EXT	G 1" 1/4 (ISO 228/1)	110	1,9 kg



G1.6 GPRS/NB-IoT/MBUS



G4 GPRS/NB-IoT/MBUS

